

TOMAHAWK

MANUFACTURING  INC.

CUBER PERFORATOR



- **Multiple Head Sizes available to fit processing needs**
- **All Stainless steel, conveyor, gear box, and frame**
- **NEMA IV enclosures**
- **Variable Frequency Drives**
- **Guards are engraved with Safety Instructions-No labels**

TOMAHAWK
MANUFACTURING  INC.

**For more information contact:
Tomahawk Mfg, Inc**

1204 Pilgrim Road • Plymouth, WI 53073
Phone: 920-458-8008



CUBER HEAD VARIATIONS

Waffle Score



The waffle blades are wider and make a square indentation on the top and bottom of the patties. These indentions create more surface area and speeds up both the freezing process and the cooking process. As shown in the picture above the indentions are retained when the patties are frozen.

Knife Score



The knife blades are much thinner and come to a sharp point. These blades are offset so they can be lowered allowing the top and bottom rollers to actually mesh together. This setup allows for stretching or knitting the patties for a homemade appearance as shown in the above photo. The head can also be raised for a lighter more cosmetic appearance.

Homestyle Roller

This roller system allows you to start with a thicker pattie or puck and roll it out for a true homemade appearance. The roller height is fully adjustable to allow you to make unique shape patties that will fit your specifications.



Transfer Conveyor

You have the ability to raise the cuber head all the way up and use the cuber just as a product conveyor. It will transfer your product without losing the registration that you may need at your packaging area. This allows you to only need one conveyor and will decrease your changeover time.



TM27 CUBER PERFORATOR

SPECIFICATIONS

- **Head Styles Available**
 - Waffle Perforating Blade – 0.130" (3.30mm) wide
 - Standard Perforating Blade – 0.062" (1.57mm) wide
 - Scoring Blade – 0.060" (1.52mm) wide
 - Knitting Blade – 0.035" (0.89mm) wide
 - Solid Roller
- **Electrically driven unit standard (hydraulic powered units by request)**
- **Adjustable Belt Speed – up to 75 Ft/min standard (faster as needed and by request)**
- **Patty thickness up to 1.25" thick**
- **Knife depth adjustment is uniform**
- **Simple knife point adjustment**
- **Knife head assemblies easily removed**
- **1 HP Motor standard (larger as needed or by request)**
- **Simple height adjustment**
- **Custom specifications available by request**

SANITATION

- **Stainless Steel Gearbox**
- **Stainless Steel Motor**
- **Stainless Steel Frame**
- **NEMA 4X electrical enclosure & liquid-tight conduit**
- **Stainless Steel wire belt standard (plastic belt available by request)**

ELECTRICAL

- **NEMA 4X Enclosure**
- **460V/60Hz 3-Phase voltage standard (optional voltages available as needed)**
- **Variable Frequency Drive**

SAFETY

- **Safety guards with proximity switch location**
- **Safety warnings etched on guards**
- **Emergency Stop switches on both sides of machine**

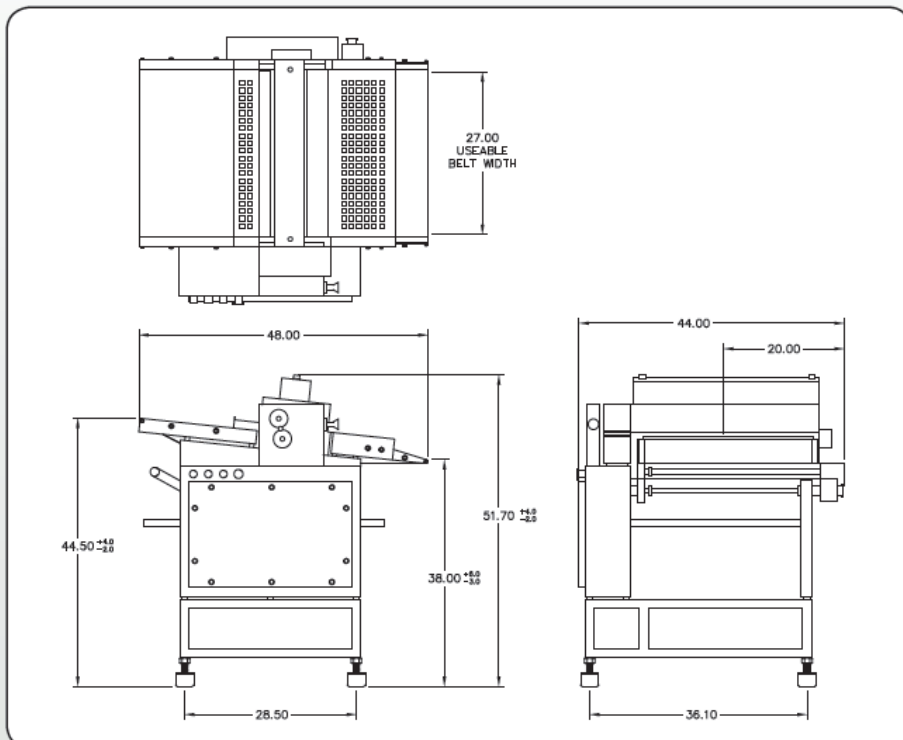

TOMAHAWK
MANUFACTURING  **INC.**

*For more information
contact:*

Tomahawk Mfg, Inc

1204 Pilgrim Road
Plymouth, WI 53073
Phone: 920-458-8008